

Selecting Your SGMAH Sigma II Servo System

First, select the Sigma II servomotor suited for your application using SigmaSize: the Yaskawa servomotor sizing software, available at no charge. (Request SigmaSize software via e-mail, at: literature@yaskawa.com).

Use the diagram below to locate and identify the components of your system. Each item is letter-coded and cross-referenced in the option tables on the following pages.

System Configuration

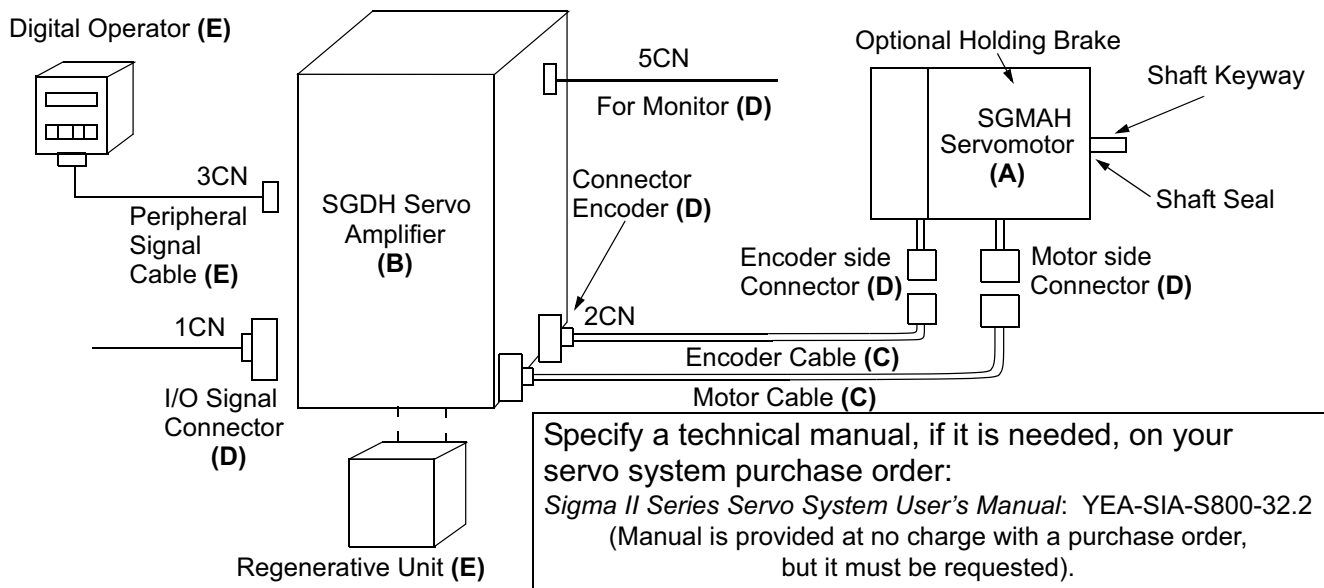

Model Number Designation

SGMAH - 01 A A F 4 1

<p>Sigma II Servomotor Type</p> <p>Rated Output</p> <p>A3: 30W (0.04hp)</p> <p>A5: 50W (0.07hp)</p> <p>01: 100W (0.13hp)</p> <p>02: 200W (0.25hp)</p> <p>04: 400W (0.5hp)</p> <p>08: 750W (1hp)</p> <p>Power Supply</p> <p>A: 200V</p> <p>B: 100V</p>	<p>Accessories</p> <p>1: Standard</p> <p>C: Standard with 24V_{DC} Brake*</p> <p>S: Standard with Shaft Seal*</p> <p>E: Standard with Brake & Shaft Seal*</p> <p>Shaft Specifications</p> <p>4: Straight Shaft with Keyway*</p> <p>2: Straight Shaft without Keyway</p> <p>Revision Level</p> <p>F: Standard</p> <p>N: NEMA flange (200W, 400W & 800W only without holding brake)</p> <p>Encoder Specifications</p> <p>A: 13-bit (2048 x 4) Incremental Encoder</p> <p>1: 16-bit (16384 x 4) Absolute Encoder</p>
---	---

* Keyways, shaft seals, and holding brakes not available on motors with NEMA flanges (revision level = N).